

# E-2010 CENTRAL CONTROL STATION

## OPERATION & INSTALLATION MANUAL

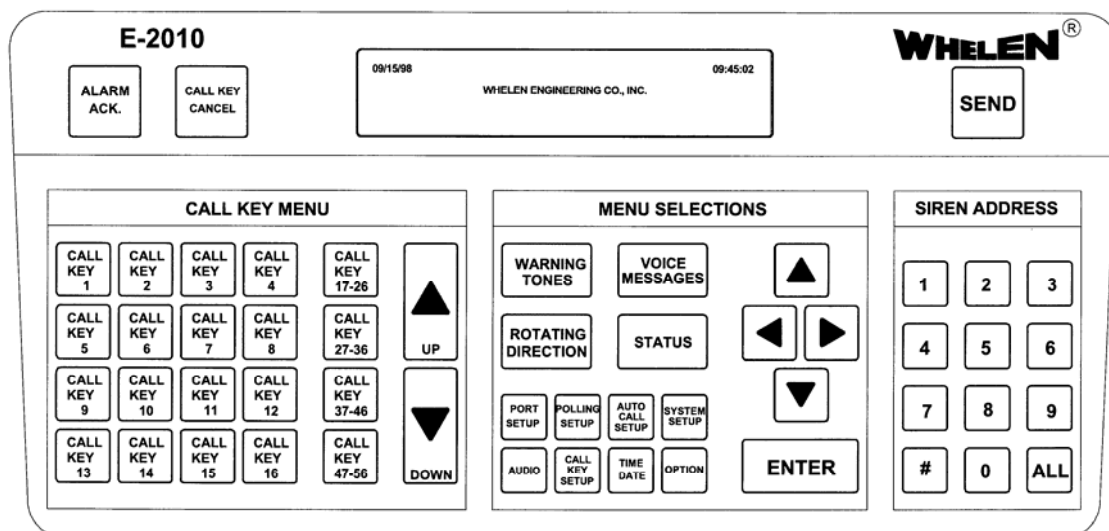



# **E-2010 CENTRAL CONTROL STATION**

## **OPERATION & INSTALLATION MANUAL**

The purpose of this manual is to provide operation and installation information about the use of a Whelen Engineering Company, Inc. Model E-2010 Central Control Station.

Prior to reading this manual or using this product you should be familiar with Whelen Engineering Company's family of High Power Voice and Siren Systems.

The information contained herein is proprietary to hss Engineering ApS and Whelen Engineering Company, Inc. No part of this manual may be reproduced, recorded or stored in a retrieval system, or transmitted, in any form without prior permission of hss Engineering ApS and Whelen Engineering Company, Inc.

The software described in this manual is supplied with the understanding that it may not be copied or otherwise redistributed without prior permission of hss Engineering ApS and Whelen Engineering Company, Inc.

All materials and specifications contained in this document are subject to change without notice.

# Table of Contents

<b>Introduction .....</b>	<b>1</b>
<b>Communication Protocol .....</b>	<b>2</b>
Area Code.....	2
Remote Siren Address Code .....	2
Identification .....	2
Command .....	2
<b>Getting Started.....</b>	<b>3</b>
Keyboard Entries.....	3
Function Definitions.....	4
<b>Menu Selections .....</b>	<b>5</b>
Warning Tones .....	5
Voice Messages.....	5
Rotation Direction .....	5
Status .....	6
Port Setup .....	6
Polling Setup .....	6
Auto Call Setup .....	7
System Setup .....	7
Audio .....	7
Call Key Setup .....	8
Time Date.....	8
Option.....	8
<b>Call Keys.....</b>	<b>8</b>
Call Key Programming.....	8
Modify a Call Key.....	9
Delete a Call Key .....	10
Finishing a Call Key.....	11
Printing an individual Call Key.....	11
Printing All Call Keys .....	11
Remote Input Call Keys .....	11
Time-Of-Day (Automatic) Call Keys .....	12
Command number table .....	12
<b>Menu Activation .....</b>	<b>13</b>
<b>Printing.....</b>	<b>14</b>
<b>Alarms .....</b>	<b>15</b>
<b>PC Interface .....</b>	<b>15</b>
<b>Installation.....</b>	<b>16</b>
<b>Troubleshooting .....</b>	<b>18</b>
<b>Specifications.....</b>	<b>19</b>

## **Introduction**

The E-2010 Central Control Station is a full function, easy to use, activation and status display unit for Whelen's family of High Power Voice and Siren System products. The E-2010 uses Whelen's standard reliable **10 digit DTMF communication protocol**.

The E-2010 is an attractive, desktop unit designed for simple connection to a base station transmitter. The E-2010 has a sealed membrane keyboard and a low power liquid crystal display. The typical warning activation sequence consists of selecting a **Call Key** or following a four step process.

There are 62 **Call Keys**, which allow the user to program and execute pre-defined scenarios. Sixteen of the Call Keys are "Hot Keys", while 40 of the Call Keys are auxiliary or low use functions. In addition, there are two Call Keys activated by Time-of-Day and four Call Keys Activated by Remote Activation inputs (as described in a later section).

Individual selection and activation may be done as follows:

1. Make a **Menu Selection**
2. Enter the four digit **Address**
3. Select the **Channel**
4. Press the **Send** button

The user may select from different command, control, status or test functions. The E-2010 supports up to 10,000 unique addresses.

The liquid crystal display (LCD) is a 4 line by 40 character configuration. The display is backlit for easy reading in low ambient light. When the E-2010 is not in use, a running 24 hour clock, day of the week and a stand by message are displayed.

Internal batteries are continuously "trickle" charged, to provide long life. The E-2010 will maintain its internal clock for up to 3 months after being unplugged. The E-2010 comes with a UL listed, plug in, AC wall mount power supply.

Two rear panel, two-piece, screw terminal connectors are available for field wiring to two base station transceivers. Each connector supports transformer coupled audio, a Push To Talk closure, Squelch monitor input (active high or low), and Channel Grant input for trunking systems.

A software interface with a PC stores all communication activity to the hard drive. In addition, this software supports advanced database handling for printing and manipulation of data.

## **Communication Protocol**

The standard communication protocol for Whelen's High Power Voice and Siren System products is a 10 digit DTMF (Dual Tone Multi-Frequency) format. This means that the activation command consists of ten DTMF digits. The status feedback from a remote siren may have from 10 to 18 digits, depending on the type of feedback status.

The activation command structure is as follows:

Digits 1-3 = System Area Code  
Digits 4-7 = Remote Siren Address Code  
Digits 8 = Identification Number  
Digits 9,10 = Command

### **Area Code**

Each warning system receives a factory assigned area code. Consideration is given to frequency allocations to minimize the chance of false activation from a neighboring system.

### **Remote Siren Address Code**

Each remote siren within a system is assigned a unique address. In order to accept a command string, the remote siren must receive the proper area code and address in the proper order, in a certain time span. A remote siren will reject any command string that does not meet these requirements.

System "all calls" are permitted through the use of the # symbol (or wildcard). The # may be used in all four address digits to communicate with all remote siren within the area code or the # may be used in specific positions to communicate with a group of remote sirens. The # may not be used in the area code.

### **Identification**

The eight digit identifies which Control Center transmitted the command. There may be up to eight centers within a system.

### **Command**

These digits define the command. This information is provided for reference only, since in the E-2010 all commands are selected by name and all response strings are decoded into specific names.

(Do not confuse this with the Command Table used in Call Key programming)

## **Getting Started**

These are some general definitions which must be understood before using the E-2010.

### **Keyboard Entries**

Send -	Pressing the Send button will transmit a function. There is no second chance or “are you sure” warning.
Call Key - Cancel	This is a dual function button. Pressing this button, while a Call Key is <u>in progress</u> , will Cancel the Call Key. In addition, this button is used during Menu Selection operations to escape or restart an operation.
Alarm - ACK	Pressing the Alarm Acknowledge button silences the internal alarm buzzer, if it is enabled. An Alarm Acknowledge message is printed. Output relays are turned off.
Up (large Up arrow)	Located in the Call Key Menu section. Used to scroll up through groups of Call Keys 17-26, 27-36, 37-46 or 47-56.
Down (large Down arrow)	Located in the Call Key Menu section. Used to scroll down through groups of Call Keys 17-26, 27-36, 37-46 or 47-56.
Enter -	Used to make selections in the Menu Selection portion of the keyboard.
#	The “wildcard” address entry, it equals numerical entries 0 through-9.
All -	A one button method for entering four # signs, for selecting all remote siren addresses in the system. This is sometimes referred to as “all call”.

## Function Definitions

### Channels -

There are two communication channels, referred to as Channel 1 and Channel 2. This allows for operating with two radio frequencies or one RF link and one landline. Transmission may be sent via either channel. Channel 1 is the default. Channel selection is part of every transmission.

### Polling -

For feedback functions, the E-2010 automatically accesses each remote siren, one at a time, based on the addresses entered in Polling Setup. This saves the user a considerable amount of time in collecting information about an entire system. To initiate a Polling function, select a Status Feedback Command. Use an address of #####, press ENTER, select the Channel and ENTER, and SEND. The following functions are supported by Polling:

Status Request

Active Status

Counter

Battery/AC

Battery/Temperature

Instant Status

Rotor Position

S/N Status

## **Menu Selections**

This section describes the function of each button in the Menu Selection portion of the keyboard. In general, the Down arrow (within the Menu Selections portion of the keyboard) is used to scroll through the functions as listed below. The Up arrow (within the Menu Selections portion of the keyboard) may also be used to scroll up through the list. The four large buttons contain actual remote siren functions, such as Warning Tones or Status Requests.

### **Warning Tones**

Cancel	Terminates all siren activity.
Wail	Activates the Wail Tone.
Attack	Activates the Attack Tone.
Alert	Activates the Alert Tone.
Public Address	Enables the Public Address mode.
Air Horn	Activates the Air Horn Tone.
Hi-Lo	Activates the Hi-Lo Tone.
Whoop	Activates the Whoop Tone
Noon Test	Activates the Noon Test Function.

### **Voice Messages**

MSG 1	Activates Digital Voice Message 1.
MSG 2	Activates Digital Voice Message 2.
MSG 3	Activates Digital Voice Message 3.
MSG 4	Activates Digital Voice Message 4.
MSG 5	Activates Digital Voice Message 5.
MSG 6	Activates Digital Voice Message 6.
MSG 7	Activates Digital Voice Message 7.
MSG 8	Activates Digital Voice Message 8.
MSG 9	Activates Digital Voice Message 9.
MSG 10	Activates Digital Voice Message 10.
MSG 11	Activates Digital Voice Message 11.
MSG 12	Activates Digital Voice Message 12.
MSG 13	Activates Digital Voice Message 13.
MSG 14	Activates Digital Voice Message 14.
MSG 15	Activates Digital Voice Message 15.
MSG 16	Activates Digital Voice Message 16.

### **Rotation Direction**

North	Positions a 4000 Series Siren to North.
East	Positions a 4000 Series Siren to East.
South	Positions a 4000 Series Siren to South.
West	Positions a 4000 Series Siren to West.
Clockwise	Increments a 4000 Series Siren 45° CW.
Counter Clockwise	Increments a 4000 Series Siren 45° CCW.
Rotor Position	Rotor/speaker position request.

## Status

Silent Test	Initiates the Silent Test function.
Inst Stat	Get real time (instant) status of Remote Siren.
Batt/Temp	Request battery voltage and cabinet temperature.
Battery/AC	Request battery voltage and AC line voltage.
Status Req	Request the Status byte.
S/N Stat	Request signal to noise measurement.
S/N Req	Executes the signal to noise check in the Remote Siren.
Siren Off	Disable the Tone Generator, digital voice is active.
Siren On	Enable the Tone Generator.
Dis-Arm	Disable the Instant Status response.
Arm	Enable the Instant Status response.
Count Clr	Clear the software tone activation counter to zero.
Counter	Request the software tone activation count.
Strobe Test	EAS only. Strobevisor test.
Strobe Off	De-activate a strobe through the Strobe Control Board.
Strobe On	Activate a strobe through the Strobe Control Board.
Test Clear	Clear LEDs and status.
Active Status	Request multiple system status parameters.

The eight small buttons are used to configure the control system. The programmable choices are presented on the display. In general, the Up and Down arrows scroll between the choices, and the Left or Right arrow toggle between the available choices, such as On or Off.

Note that in Auto Call Setup the Left and Right arrows scroll between the choices and the Up and Down arrows toggles between YES or NO.

## Port Setup

Setup for the RS-232 communication port and the Printer port. The RS-232 port is dedicated to a PC operating Whelen supplied software. The parameters are:

Printer	On or Off	Use the Left or Right arrow to toggle
Serial Port	On or Off	Use the Left or Right arrow to toggle

Printing and serial interface are discussed in other sections. Set to OFF if not used.

## Polling Setup

Setup for Status polling routine. This is a list of all of the remote siren address in the system. Unused entries display as "EMPTY". To delete an entry, select "ALL".

## Auto Call Setup

Setup for automatic Time-of-Day Call Keys. A Call Key may be programmed to activate by day of the week and by the time of day. Time is entered as military time (24 hour time). The Call Key must still be programmed in the CALL KEY SETUP section. The Time-of-Day Call Keys are referred to as Call Key #61 and #62.

Use the Left or Right arrows to scroll through the days of the week. Use the Up or Down arrows to toggle between Y to select the day or N to not select the day. The days are Sunday through Saturday. To get to the time, scroll right past the last S, for Saturday. Enter the activation time, in military (24 hour time), from the numeric keypad. Use the Left or Right arrows to move from time to the other Call Key. Do not use the scroll arrows in the time section, unless moving to the other Call Key. Press ENTER to save the setup.

## System Setup

Setup for system variables. Use the Up or Down arrows to move through the choices. The following parameters are set in this section:

Area Code	3 digits. A value other than 000 must be entered.
Xmitter Up	Radio transmitter warm up time, in seconds or tenths of seconds. A value other than 0 must be entered.
Base ID	Base Station identification number, 0-7, for systems with more than one E-2010.
Ch Grant Wait	Channel grant waiting time, in seconds. For trunking radios only. The time that the E-2010 waits until aborting a transmission, if Channel grant is not received.
Ch Grant Delay	Channel grant delay time, in seconds. The time that the E-2010 holds off the transmission following the receipt of Channel Grant.

## Audio

Audio output control. Use the Up or Down arrows to move through the choices. The following functions are set in this section:

Speaker	The speaker may be Off or set to Radio Channel 1 or 2. The speaker monitors any audio on the selected Channel.
Microphone	The public Address microphone may be Off or set to Radio Channel 1 or 2.
Buzzer	The Low Battery or Intrusion Alarm Buzzer may be On or Off.

## Call Key Setup

Setup for all Call Keys. Refer to the Call Key Section of the Manual.

### Time Date

Routines for entering current time and date. Use to set the day of the week, the time and the date. Day of week must be set for Auto Call Keys. Use the Up or Down arrows to select the day. Use the numeric keypad to set time and date. Time is military time (24 hour time).

### Option

Reserved for future use.

**NOTE:**  
While in the Menu Selections portion of the keyboard, pressing CALL KEY CANCEL will return the E-2010 to the standby screen.

## Call Keys

Call Keys are the easiest way to manage a siren system, for typical day-to-day situations. In general, a Call Key is a preprogrammed scenario or sequence of commands, where each command is separated by a time period. For example, a Wail command is issued to all addresses, followed by a one minute run period, then a Cancel is sent, followed by a five second period, next a Digital Voice command is sent, followed by a 30 second period, then a Cancel, followed by a five second period, and so on. The Call Key may contain any of the commands listed in the Command Table. Each entry is referred to as a sequence. A single Call Key may have up to 99 sequences (01-99), however, the total number of Call Key sequences must be less than 2500. When a Call Key is selected and sent, it starts with sequence 01 and continues until the last programmed sequence, it does not repeat. A Call Key can not activate another Call Key.

There are a total of 62 Call Keys in the E-2010. Sixteen of the Call Keys are “hot” Call Keys, that is, they are available at the press of a single button, followed by SEND. These are labeled Call Key 1 through Call Key 16. Four additional buttons provide 40 auxiliary Call Keys, in groups of ten. To use an auxiliary Call Key, press the group button, use the large Up or Down arrows to scroll to the desired Call Key and press SEND. Four more Call Keys, numbers 57-60, are activated by remote inputs. These are described in another section. Call Key 61 and Call Key 62 are available as Time-of-Day functions. These are described in another section.

A Call Key in progress may be canceled by pressing the CALL KEY CANCEL button.

### Call Key Programming

Call Keys are programmed one sequence at a time. Each sequence consists of a sequence number, a command (entered by command number from the Command Number Table), a time (the time period before the next sequence) and finally the selection of an Edit function.

Normally the function will be Insert, when creating a new Call Key. However, it may be Modify, Finish or Delete. These will be discussed later. The small Down arrow is used to scroll through the Call Key programming routine. Upon entering the Call Key Setup, a screen will appear as shown.

```
CALL KEY SETUP MENU

CALL KEY = >#
EDIT MODE = OFF    PRINT MODE = OFF
```

The cursor is the small arrow pointing to the right. With the cursor at the Call Key # entry, use the numeric keypad to type the number of the Call Key which is to be programmed.

Use the small Down arrow (in the Menu Selection portion of the keyboard) to move the cursor to Edit Mode. Use the Left or Right arrow to toggle the Edit Mode to ON. Press ENTER. A new programming screen will appear as shown.

```
SEQ #01  CHAN 1  >S#1
CMD=>          S#2
ADDR=          S#3
TIME=          EDIT=  INSERT
```

The cursor is at the command prompt. Referring to the Command Number Table, type a command number, from the numeric keypad. Use the small Down arrow to move the cursor to the Address prompt. Type the address from the numeric keypad. Use the small Down arrow to move the cursor to the time prompt. Type the time, in seconds, between this sequence and the next sequence. Use leading zeroes for values less than 100 seconds. Use the small Down arrow to move the cursor to the EDIT= prompt. Press ENTER. S#1 now displays the first sequence. Program sequence 2, starting with the command and continue as above.

After inserting the last sequence, scroll Down to Edit, then use the Left or Right arrow to select Finish and press ENTER.

### Modify a Call Key

A Call Key may be modified one Sequence at a time. Enter Call Key Setup, a screen will appear as shown.

```
CALL KEY SETUP MENU

CALL KEY = >#
EDIT MODE = OFF    PRINT MODE = OFF
```

The cursor is the small arrow pointing to the right. With the cursor at the Call Key # entry, use the numeric keypad to type the number of the Call Key which is to be modified.

Use the small Down arrow (in the Menu Selection portion of the keyboard) to move the cursor to Edit Mode. Use the Left or Right arrow to toggle the Edit Mode to ON. Press ENTER. A new programming screen will appear as shown.

```
SEQ #01  CHAN 1  >S#1
CMD=>          S#2
ADDR=         S#3
TIME=         EDIT=  MODIFY
```

The cursor is at the command prompt. Use the Down arrow to scroll the cursor around to the Sequence #. Use the Left or Right arrow to move through to the desired Sequence #. Use the Down arrow to scroll to the parameter that is to be modified. Type in the modification. Use the Down arrow to scroll to EDIT=, use the Left or Right arrow to select Modify, press ENTER.

After completing any modifications, scroll Down to Edit, then use the Left or Right arrow to select Finish and press ENTER.

### Delete a Call Key

A Call Key may be deleted one Sequence at a time. Enter Call Key Setup, a screen will appear as shown.

```
CALL KEY SETUP MENU

CALL KEY = >#
EDIT MODE = OFF  PRINT MODE = OFF
```

The cursor is the small arrow pointing to the right. With the cursor at the Call Key # entry, use the numeric keypad to type the number of the Call Key which is to be deleted.

Use the small Down arrow (in the Menu Selection portion of the keyboard) to move the cursor to Edit Mode. Use the Left or Right arrow to toggle the Edit Mode to ON. Press ENTER. A new programming screen will appear as shown.

```
SEQ #01  CHAN 1  >S#1
CMD=>          S#2
ADDR=         S#3
TIME=         EDIT=  DELETE
```

The cursor is at the command prompt. Use the Down arrow to scroll the cursor around to the Sequence #. Use the left or Right arrow to move through to the desired Sequence #. Use the Down arrow to scroll to the parameter that is to be deleted. Use the Down arrow to scroll to EDIT =, use the Left or Right arrow to select Delete, press ENTER.

After completing any deletions, scroll Down to Edit, then use the Left or Right arrow to select Finish and press ENTER.

## Finishing a Call Key

All operations, such as, inserting, modifying or deleting, must be completed before finishing with a Call Key. To Finish, use the Down arrow to scroll through to the EDIT = option. Use the Left or Right arrow to select Finish and press ENTER.

## Printing an individual Call Key

Call Keys may be printed individually or in entirety. To print a single Call Key, press Call Key Setup, a screen will appear as shown.

```
CALL KEY SETUP MENU

CALL KEY = >#
EDIT MODE = OFF   PRINT MODE = OFF
```

The cursor is the small arrow pointing to the right. With the cursor at the Call Key # entry, use the numeric keypad to type the number of the Call Key which is to be printed. Use the Down arrow to scroll to PRINT MODE =. Use the Left or Right arrow to toggle to On. Press ENTER to print.

## Printing All Call Keys

To print all Call Key, press Call Key Setup, a screen will appear as shown.

```
CALL KEY SETUP MENU

CALL KEY = >#
EDIT MODE = OFF   PRINT MODE = ALL
```

Use the Down arrow to move the cursor to PRINT MODE =. Use the Left or Right arrow to toggle to ALL. Press ENTER to print all of the Call Keys.

## Remote Input Call Keys

The E-2010 may be activated from four remote inputs. The typical remote input circuit is shown. A contact closure, capable of sinking at least 10 mA, will activate the E-2010. The closure must remain active for a minimum of ½ a second.

The remote input activates Call Keys #57, #58, #59 or #60. These Call Keys are programmed just like Call Keys 1-56 as previously described.

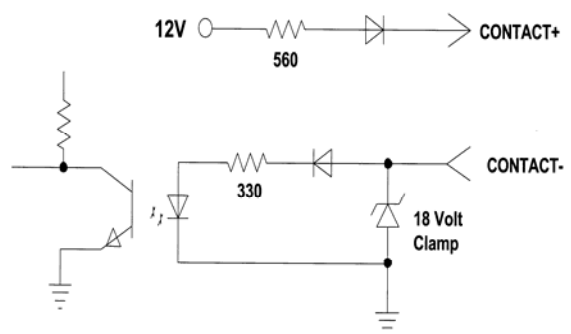

## Time-Of-Day (Automatic) Call Keys

There are two Call Keys that will automatically activate based on the day of the week and the time of the day. Refer to Auto Call Setup for more information.

These Call Keys are #61 and #62. These Call Keys are programmed just like Call Keys 1-56, as previously described.

**NOTE:**

Any active Call Key may be terminated by pressing CALL KEY CANCEL. The E-2010 will return to the standby screen.

## Command number table

00 = Cancel	49 = Voice Message 1	09 = North	15 = Silent Test
01 = Wail	50 = Voice Message 2	10 = East	63 = Active Status
02 = Attack	51 = Voice Message 3	11 = South	30 = Test Clear
03 = Alert	52 = Voice Message 4	12 = West	57 = Strobe On
04 = Public Address	53 = Voice Message 5	13 = Clockwise	58 = Strobe Off
05 = Air Horn	54 = Voice Message 6	14 = Counter Clockwise	37 = Strobe Test
06 = Hi Lo	55 = Voice Message 7	21 = Rotor Position	22 = Counter
07 = Whoop	56 = Voice Message 8		23 = Counter Clear
08 = Noon Test	59 = Voice Message 9		24 = Arm
	60 = Voice Message 10		25 = Dis-Arm
	61 = Voice Message 11		26 = Siren On
	62 = Voice Message 12		27 = Siren Off
	17 = Voice Message 13		28 = S/N Request
	18 = Voice Message 14		29 = S/N Status
	19 = Voice Message 15		31 = Status Request
	20 = Voice Message 16		33 = Battery/AC
			34 = Battery/Temperature
			35 = Instant Status

## Menu Activation

As an alternative to Call Keys, a second way of operating the E-2010 is to use a 4 step procedure of selecting individual functions and addresses through the Menu Selections and Siren Address sections of the Keyboard.

**Step 1** involves the center portion of the keypad, as shown. Choose from the Menu Selections by pressing one of four large buttons, as previously described. The display will show the first entry in the selected group. Use the Up or Down arrows to scroll through the functions, within the selected group, stopping at the desired function. Typically, scrolling starts with the Down arrow.

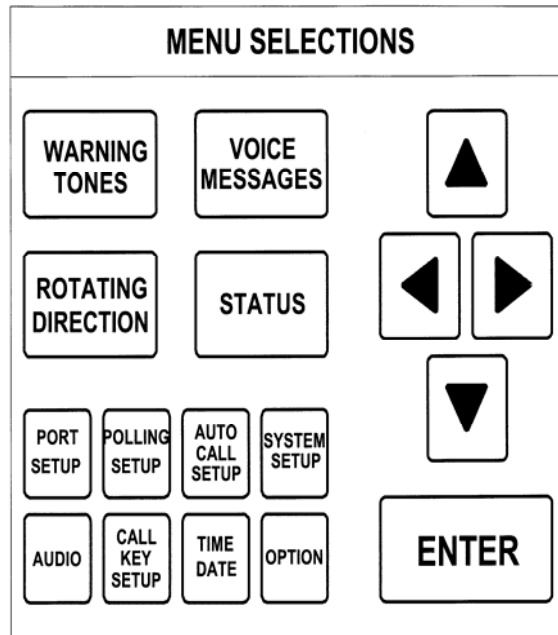

The four large buttons are directly related to Remote Siren activation and status. The eight smaller buttons are Setup and Configuration controls. Do not access one of eight smaller buttons during activation.

**Step 2** involves the right-hand portion of the keypad, as shown. Enter the four digit address of the target remote siren. The address is entered with the most significant bit first. The # sign represents a “wildcard” or all values 0 to 9. ALL is a quick way to enter four # signs, to select all sirens in the system. Press “ENTER” to accept the screen and to continue.

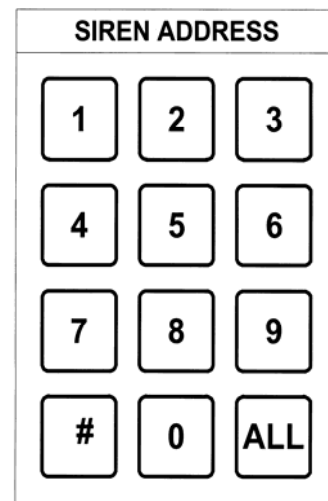

Example: To enter the address 1234, the press 1 first, then 2, then 3, and 4 is last. The display will change as shown below.

ADDR = 1???  
ADDR = 12??  
ADDR = 123?  
ADDR = 1234

Note that entering more than four values will “bump” the address to the left. For instance, assume the user presses the 5 key, at the end of the previous example. The address will change to 2345.

**Step 3** consists of selecting communication channel 1 or 2. The default is 1. Press “ENTER” to accept the screen and to continue.

**Step 4**, press “SEND” to make the transmission. **This sends the command. There is no second chance!!**

## Printing

The E-2010 supports an OKIDATA 184, 9 pin, dot matrix printer. All communication activity, information that is transmitted or received, is printed. A typical printout consists of: Time, Type (transmit or receive), Channel #, Raw Message (DTMF string), and the Decoded Message as shown.

<u>TIME</u>	<u>T/R</u>	<u>CHAN#</u>	<u>RAW MESSAGE</u>	<u>DECODED MESSAGE</u>
09:25:56	TMX	CHAN#1	123-4502-101	ENCODER#1 WAIL
09:26:14	TMX	CHAN#1	123-4502-13F	ENCODER#1 ACTIVE STATUS
09:26:16	REC	CHAN#1	123-4502-8FF-0100AD00	ACTIVE STATUS
				ACTIVE CMD- WAIL
				DRIVER/AMPS- FAIL
				BIAS OFF
				INTRUSION OK
				STROBE OK
				SUPERVISION OK
				BATTERY VOLTAGE - 23.7VDC
				AC VOLTAGE - OVAC

In addition to the typical printout, the E-2010 prints the results of a polling function for quick reference, as shown.

POLLING RESULTS	
SIRENS POLLED	-4
NO RESPONSE	-1
4503	
STATUS ERRORS	-1
4506	
LOW BATTERY	-0
LOW AC PWR	-1
4506	

The E-2010 will store a small amount of print information if the printer is disconnected or turned off. Typically, this is from 6 to 8 lines of data. This buffer is printed when the printer is reconnected or turned back on.

The proper way to prevent printing is to select printer Off, through the Port Setup function, in Menu Selections.

The printer is an option. Refer to the Okidata manual for more information regarding printer operation.

## Alarms

There are two remote siren conditions which will cause an alarm in the E-2010. They are Low Battery and Intrusion.

Upon receipt of either alarm, the E-2010 sounds the internal buzzer (assuming it is enabled, see AUDIO in the Menu Selections section) and activates the appropriate output relay. There are two relay closures. One is for Low Battery and one is for Intrusion. Each closure is rated at ½ amp @ 120 VAC or 1 amp @ 24 VDC. The connections are described in the Installation section.

Pressing ALARM ACK silences the buzzer and turns off the relay.

## PC Interface

If desired, the E-2010 can interface with a personal computer (IBM compatible running Windows 95) through an RS-232 Serial Communication port. Software is included to allow for the following:

- Storing data to the hard drive
- Selectable printing based on site or data
- Call Key programming (instead of using the E-2010 keyboard)
- Call Key descriptions
- Storing data in a format compatible with Microsoft Access

Follow the installation instructions on the CD-ROM to install and operate the interface software. Use the 9 position D connector cable to connect the Serial port of the E-2010 to a Serial communication port on the PC.

**NOTE:**

The E-2010 operates independent of the PC. Therefore, even if the PC is doing something else or is **off**, the E-2010 continues to operate normally.

## Installation

This step-by-step procedure for installing the E-2010 is intended for use by a qualified radio technician. A Phillips screwdriver and a very small flat blade screwdriver will be required for setup.

1. Inspect the E-2010 for any physical damage.

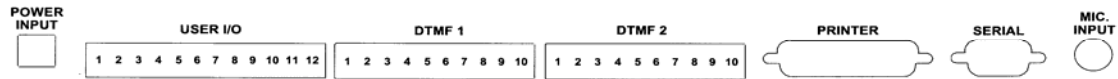

2. Look at the rear panel. From left to right are the following:

AC/DC wall mount power input plug.  
 User I/O connections.  
 DTMF Channel 1 connections.  
 DTMF Channel 2 connections.  
 Printer connector to Okidata.  
 Serial connector to PC.  
 Microphone input jack.

3. Make the Channel 1 DTMF transceiver (and Channel 2, if used) connections at pins 1 through 10. Channel Grant applies to trunking systems only.

<u>Pin</u>	<u>Signal</u>	
1	Push To Talk	Output
2	Push To Talk	Output
3	Audio Out	Output
4	Audio Out	Output
5	Squelch In	Input
6	Ground	
7	Channel Grant	Input
8	Audio In	Input
9	Audio In	Input
10	Ground	

4. Make any User I/O connections at the 12 position connector as follows:

<u>Pin</u>	<u>Signal</u>	
1	Remote Closure 2	Output (Intrusion)
2	Remote Closure 2	Output
3	Remote Closure 1	Output (Low Battery)
4	Remote Closure 1	Output
5	Remote Call Key 1	Input (Call Key 57)
6	Remote Call Key 1	Input (Call Key 57)
7	Remote Call Key 2	Input (Call Key 58)
8	Remote Call Key 2	Input (Call Key 58)
9	Remote Call Key 3	Input (Call Key 59)
10	Remote Call Key 3	Input (Call Key 59)
11	Remote Call Key 4	Input (Call Key 60)
12	Remote Call Key 4	Input (Call Key 60)

5. Remove the two upper Phillips Head screws from each side and three from the back of the unit to access the circuit board. **Slowly** lift the cover off, trying not to pull any of the connections apart. Locate the jumpers and adjustment potentiometers in the center section of the circuit board.

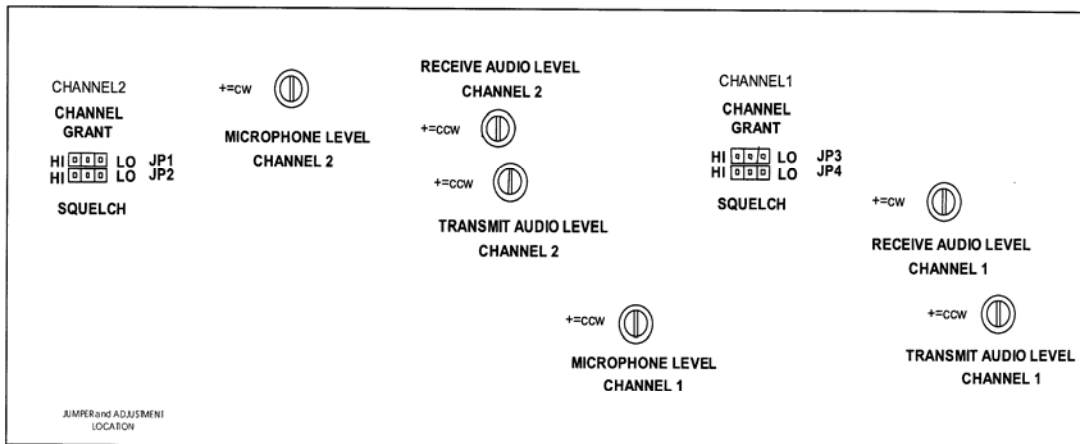

6. The **Squelch** signal and the **Channel Grant** signal (Channel Grant is for trunking radio transceiver only) may be active high or active low. The active state must be set by two jumpers, inside of the E-2010. The settings must be made for both channels, if both are in use. Determine the active state of the radio transceiver Squelch signal, and the Channel Grant signal (if applicable) and set the jumpers, as shown to the right. Place the jumper in the “H” position for active high or “L” for active low. Factory settings are active high.
7. Plug the AC wall mount into a 115 volt AC source.
8. Set the DTMF **Transmit Audio Level**, for **Channel 1**. With the E-2010 on, Send the CANCEL Command to siren address 0001. While the tone is transmitting, adjust the level potentiometer for 2.5 KHz deviation. Repeat this step as needed to adjust the level. Repeat for Channel 2, if required.
9. Set the **Microphone Level**, for **Channel 1**. Plug the microphone into the MIC jack. Key up the microphone and adjust the Microphone Level potentiometer for 4 KHz deviation, while speaking into the microphone.  
  
Note: The microphone is not included. Refer to Model WPSNCMIC, part #01-0245719-00.
10. **Receive Audio Level** is factory set for an input signal of 0 to –10dB.
11. The speaker volume potentiometer is located through the small access hole on the right side of the E-2010.

Located at the left rear of the E-2010 is a **security keylock**. Turning the key off will disable all keyboard entries.

## **Troubleshooting**

### **Problem**

### **Solution**

Display and backlight are blank.

Check AC power and DC power pack connection.

Time clock is active, keyboard does not function.

Security switch is off.

Command is sent, but display still reads “transmitting”.

Area code is still at 000, must be set. Transmitter warm-up is still 0.0, must be set to a value other than 0.

No PC Interaction.

Cable is not connected or the serial port is “off” in Port Setup.

No printer interaction.

Cable is not connected or the printer port is “off” in Port Setup.

Polling function does not work.

Remote siren addresses were not entered in Polling Setup.

Time clock does not maintain time.

Check internal battery voltage. Replace if less than 2.5 volts DC.

## Specifications

### General –

<b>Input Power:</b>	12 volt DC nominal, 185 mA typ., 300 mA max. UL listed wall mounted transformer.
<b>Physical:</b>	Desktop design, almond color. 3” H x 17” W x 9” D. 4.5 pounds.
<b>Environmental:</b>	Operating temperature, 0°C to +60°C. Storage temperature, -20°C to +60°C. Humidity, 0-95%, non-condensing.
<b>Audio:</b>	2 wire, 600 $\Omega$ transformer balanced, adjustable.
<b>Control:</b>	Normally open relay for Push To Talk. Contact rating, ½ A @ 120 VAC, 1 A @ 24 VDC.
<b>Signaling:</b>	DTMF format, 2 of 8, Whelen 10 digit protocol.

### Rear Panel –

<b>DTMF Tone Level:</b>	Variable, 0-4 Vpp.
<b>Microphone Volume:</b>	Variable, 0-6 Vpp.
<b>Microphone Jack:</b>	Ground, Signal, PTT.
<b>Relay Closure Outputs:</b>	(2) Rated at ½ Amp @ 120 VAC, 1 Amp @ 24 VDC.
<b>Connectors:</b>	Two part, screw terminal, Phoenix brand or equivalent.